

## BFS-18 Series

### Features

- Complying with IEC 60947-5-1
- Silver Contact
- Rugged design
- Highly Reliable
- Easy to Operate
- Available in dual-pedal versions
- Light weight Aluminum body



CE RoHS

### Design

BRISK Brand Foot Switches are single and double pole change over snap action switches featuring exceptional repeat accuracy and strict quality control with silver contacts. Solution for applications requiring a precision lightweight or medium weight foot control.

## Technical Specification

### Electrical Specification

Rating	: 10A / 500V AC
Contact Resistance	: 10 m $\Omega$
Insulation Resistance	: 100 M $\Omega$
Electrical Life	: 1 lakh operation
High Voltage Test	: 1 KV AC between open contacts

### Mechanical Specification

Contact	: Silver contact
Terminal	: Brass
Body	: Aluminum die casting
Mechanical Life	: 1 million operation

### Additional Information

M20X1.5 mm Conduit entry

## Ordering code

Product Code	Description	Contact Form	Rating
BFS-18 / LS	Double Pedal Foot Switch, With Guard, Without Wire	2 DPDT-CO	10A/ 500 V AC
BFS-18 / X2	Double Pedal Foot Switch, With Guard, Without Wire	2 SPDT-DB	10A/ 500 V AC
BFS-18 / XX2	Double Pedal Foot Switch, With Guard, Without Wire	2 DPDT-DB	10A/ 500 V AC

**Contact form**

DPDT-CO

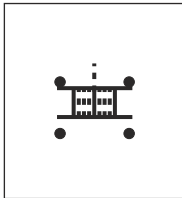

SPDT-DB

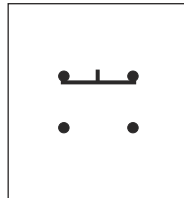

DPDT-DB

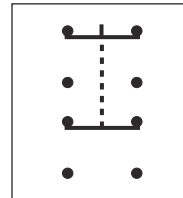
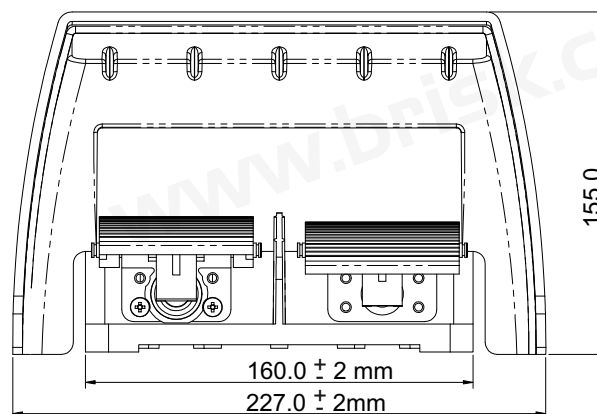
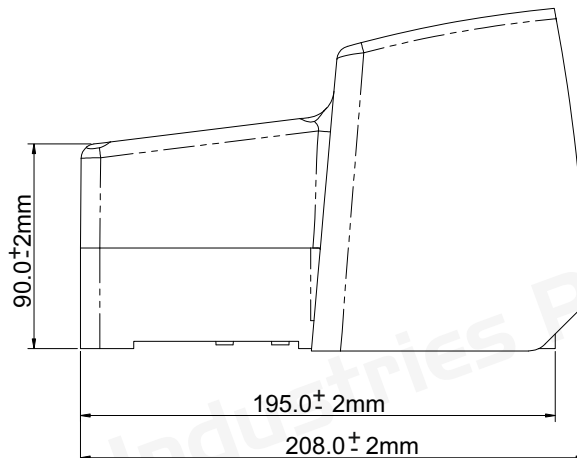
**Dimensions****All Dimensions are in mm**