

BFS-12 Series



CE RoHS

Features

- Complying with IEC 60947-5-1
- Complying to IP 67
- Silver Contact
- Rugged design
- Highly Reliable
- Easy to Operate
- Light weight Aluminum body

Design

BRISK Brand Foot Switches are single and double pole change over snap action switches featuring exceptional repeat accuracy and strict quality control with silver contacts. Solution for applications requiring a precision lightweight or medium weight foot control.

Technical Specification

Electrical Specification

Rating	: 10 A / 500V AC,
Contact Resistance	: 10 m Ω
Insulation Resistance	: 100 m Ω
Electrical Life	: 1 lakh operation
High Voltage Test	: 1 KV AC between open contacts

Mechanical Specification

Contact	: Silver Contact
Terminal	: Brass
Body	: Aluminum pressure die casting
Cover	: 1) Aluminium die casting 2) Available in unbreakable polycarbonate material. Please add suffix 'PC' for polycarbonate cover as shown in ordering code table
Mechanical Life	: 1 million operation .

Ordering code

Standard Models : Delivery 3 Weeks

Product Code	Description	Contact Form	Rating
BFS-12 / X	Heavy Duty Foot Switch , With Aluminium Cover	SPDT-DB	10A/ 500 V AC
BFS-12 / XX	Heavy Duty Foot Switch , With Aluminium Cover	DPDT-DB	10A/ 500 V AC
BFS-12 / X / PC	Heavy Duty Foot Switch , With Polycarbonate Cover	SPDT-DB	10A/ 500 V AC
BFS-12 / XX / PC	Heavy Duty Foot Switch , With Polycarbonate Cover	DPDT-DB	10A/ 500 V AC

Note : All other customised Models will have delivery of 5 Weeks and Minimum Order Quantity (MOQ) is applicable.

Product Code	Description	Contact Form	Rating
BFS-12 / X / L	Heavy Duty Foot Switch , With Latching, With Aluminium Cover	SPDT-DB	10A/ 500 V AC
BFS-12 / XX / L	Heavy Duty Foot Switch , With Latching, With Aluminium Cover	DPDT-DB	10A/ 500 V AC
BFS-12 / X / L / PC	Heavy Duty Foot Switch , With Latching, With Polycarbonate Cover	SPDT-DB	10A/ 500 V AC
BFS-12 / XX / L / PC	Heavy Duty Foot Switch , With Latching, With Polycarbonate Cover	DPDT-DB	10A/ 500 V AC
BFS-12 / X2	Heavy Duty Foot Switch , With 3 Position, With Aluminium Cover	2 SPDT-DB	10A/ 500 V AC
BFS-12 / XX2	Heavy Duty Foot Switch , With 3 Position, With Aluminium Cover	2 DPDT-DB	10A/ 500 V AC
BFS-12 / X2 / PC	Heavy Duty Foot Switch , With 3 Position, With Polycarbonate Cover	2 SPDT-DB	10A/ 500 V AC
BFS-12 / XX2 / PC	Heavy Duty Foot Switch , With 3 Position, With Polycarbonate Cover	2 DPDT-DB	10A/ 500 V AC
BFS-12 / XX / P5K	Foot Switch , With 5K Ohms POT, With Aluminium Cover	DPDT-DB	10A/ 500 V AC
BFS-12 / XX / P10K	Foot Switch , With 10K Ohms POT, With Aluminium Cover	DPDT-DB	10A/ 500 V AC
BFS-12 / XX / P5K / PC	Heavy Duty Foot Switch , With 5K Ohms POT, With Polycarbonate Cover	DPDT-DB	10A/ 500 V AC
BFS-12 / XX / P10K / PC	Heavy Duty Foot Switch , With 10K Ohms POT, With Polycarbonate Cover	DPDT-DB	10A/ 500 V AC
POT P5K/ POT P10K	Element - Potentiometer of 5K Ohm OR 10K Ohm	-	-

Contact form

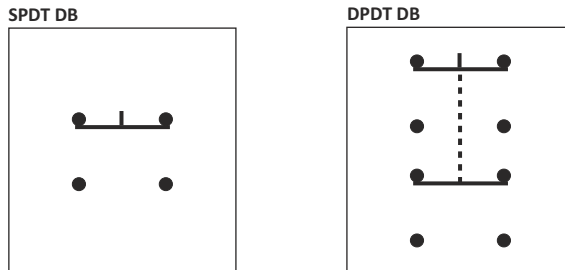

Dimensions

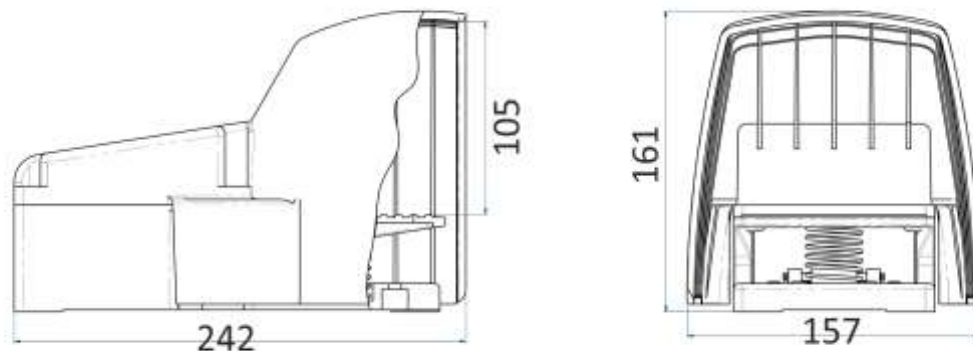

All Dimensions are in mm